

# LINE OF FIRE

The hierarchy of controls shows which measures are most effective



Source: Safety, leadership and learning, The Federation of Norwegian Industries, 2025

# LINE OF FIRE

1. Moving vehicles and mobile equipment



2. Mechanical lifting and hoisting

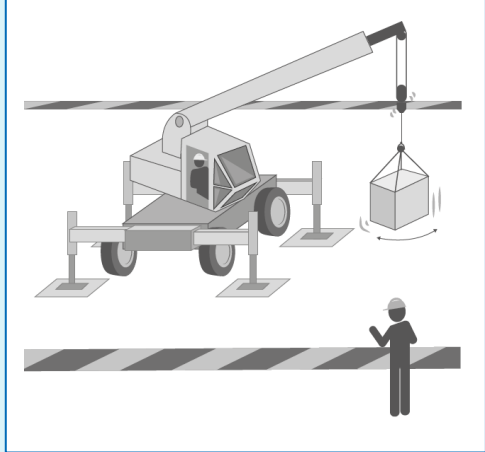

3. Work at height, falls and dropped objects

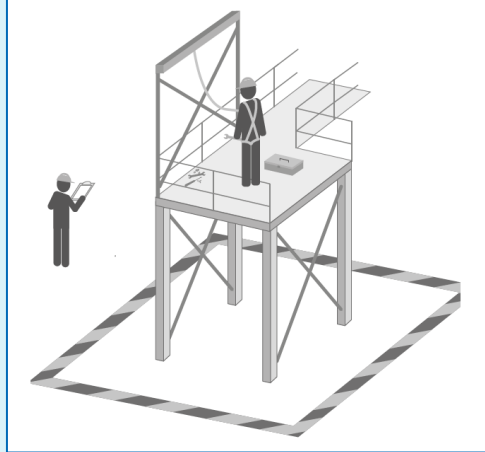

4. Tensioned lines, spring loaded devices and stored energy

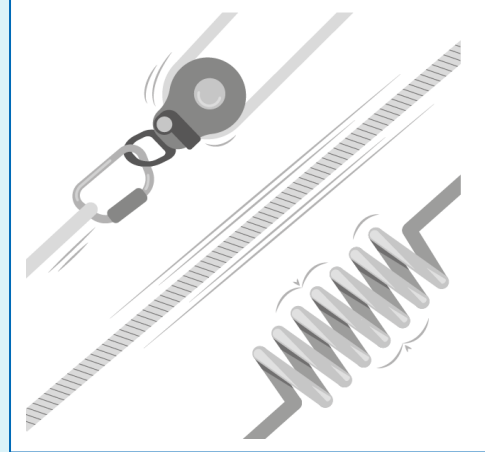

5. Uncontrolled rolling, sliding or falling

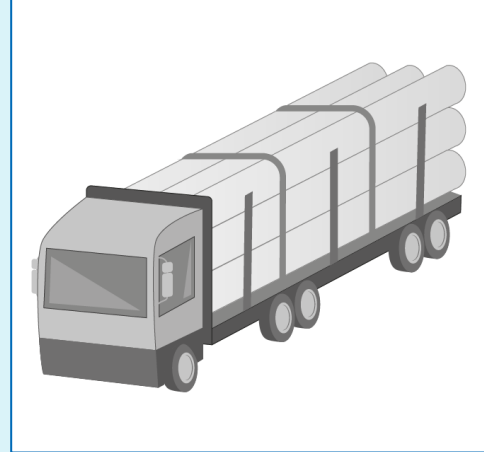

6. Pressurized systems and vacuum systems

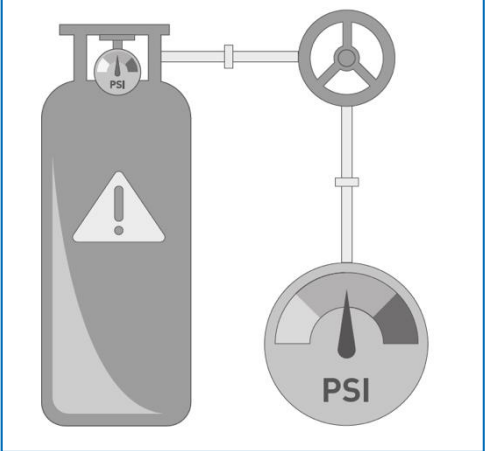

7. Machinery and tools

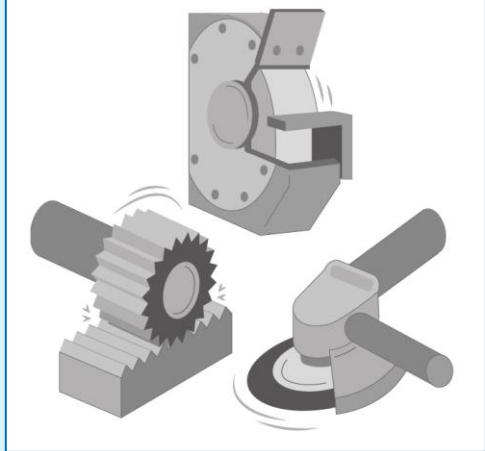

8. Electrical equipment and exposure

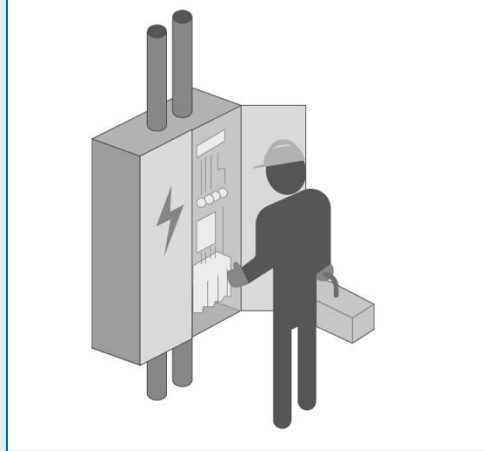

9. Projectiles, explosion and jet fire



10. Natural environmental events and extreme weather

