

# I SKUDDLINJEN

Tiltakshierarkiet viser hvilke tiltak som er mest effektive



# I SKUDDLINJEN

## 1. Kjøretøy og mobilt utstyr



## 2. Mekanisk løfting og heising

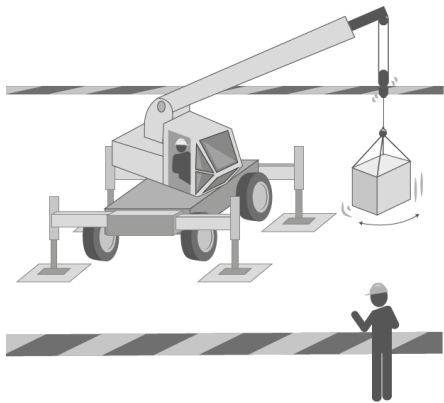

## 3. Arbeid i høyden, fall og fallende gjenstander

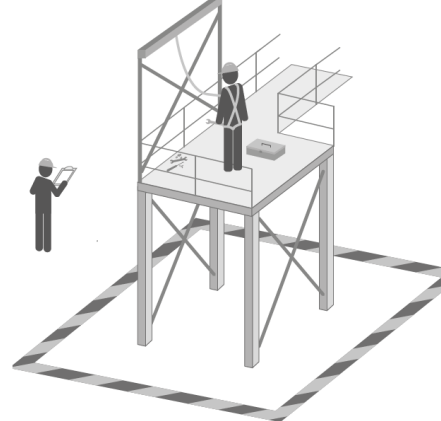

## 4. Spente liner, fjærer og lagret energi

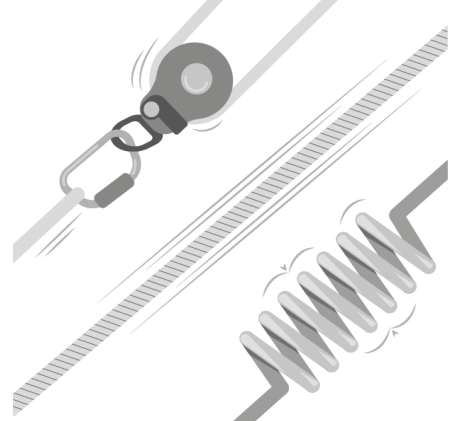

## 5. Ukontrollert rulling, skyving og fall

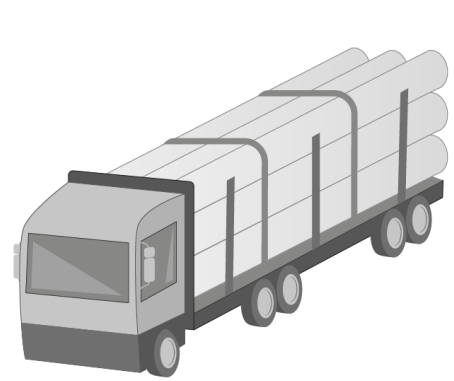

## 6. Trykksatte systemer og vakuumsystemer

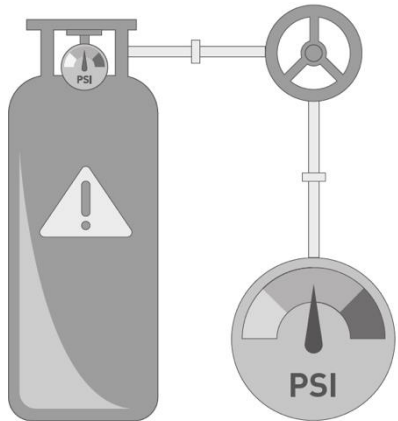

## 7. Maskiner og verktøy

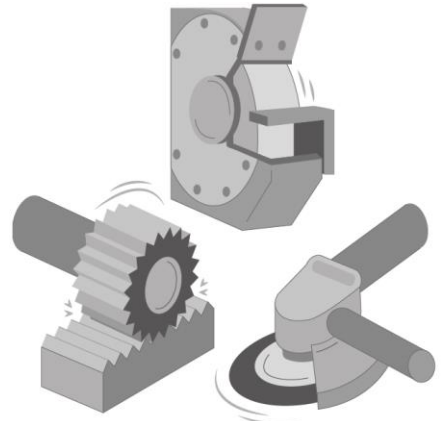

## 8. Elektrisk utstyr og eksponering

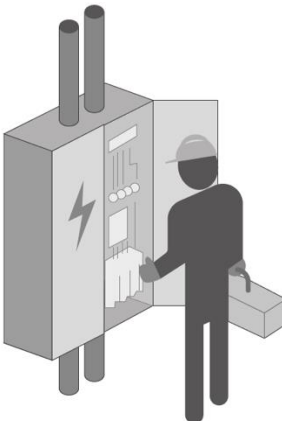

## 9. Prosjektiler, eksplosjon og jetbrann



## 10. Naturhendelser og ekstremvær

